

# Audicy Workstand Assembly Instructions

## ***Before You Begin***

***Before proceeding***, read through these instructions.

This kit contains:

- 1 Stand Base
- 4 Uprights
- 1 Monitor Shelf
- 1 Console Shelf
- 1 Power Supply Bracket
- 2 Nut Plates
- 4 Casters (with Brake, Body and Stem)
- 2 End Caps
- 2 Upright Plugs
- 2 Push-Pull Latches (aka Adjustable Clamping Handles)
- 4 Nylon Standoffs, ¼ Round, 8-32 x ½"
- 2 Screws, 3/8-16 x 1", Skillet Head
- 1 Allen Wrench, 5/16"
- 4 Screws, ¼-20 x 0.5", Button Head
- 1 Allen Wrench, 5/32"
- 5 Screws, M4 x 6.0mm, Pan Head
- 1 Modesty Panel
- 4 Hex Nuts, 3/8-16
- 4 Screws, 10-32 x ½" Pan Head
- 4 O-Ring Spacers, 3/16" x 7/16"
- 2 Thumbscrews, M4 x 0.7 x 11mm
- 2 Washers, Flat, M4, Steel
- 1 Assembly Instructions

You will need the following:

- 1 Crescent Wrench, 6"
- 1 Phillips Screwdriver, #1
- 1 Regular Screwdriver with small tip

**Step 1: Install Casters and End Caps to Front of Stand Base**

**Note:** Complete the following steps if Casters and End Caps are not already attached to the front of the Stand Base.

- A) Screw two Casters into the nuts on the curved underside portion of the Base.
- B) Press the two End Caps into the frame.

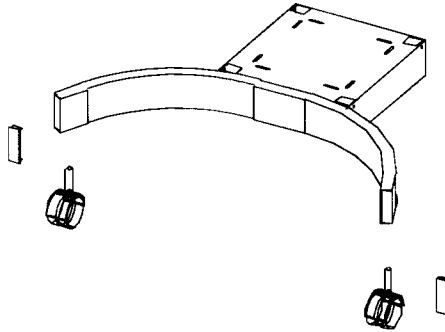

Figure 1: Installing Casters and End Caps to Stand Base

## Step 2: Attach Uprights to Stand Base

- A) Install two Uprights into the rear shoulder rivets of the Stand Base by sliding Uprights into rivet slots.
- B) Screw Hex Nuts to Casters.
- C) Screw the rear Uprights to the Base with two Casters.
- D) Install two Uprights into the front shoulder rivets of the Stand Base by sliding Uprights into rivet slots.

**Important:** Make sure open slots on the 'front' Uprights face toward the front of the stand. This is where you will attach the Console Shelf.

- E) Screw the front Uprights to the Base with two 3/8-16 x 1" Allen Head Cap Screws.

Tighten screws to bottom of Base using the supplied 5/16" Allen wrench.

**Important: Do Not Overtighten Screws!**

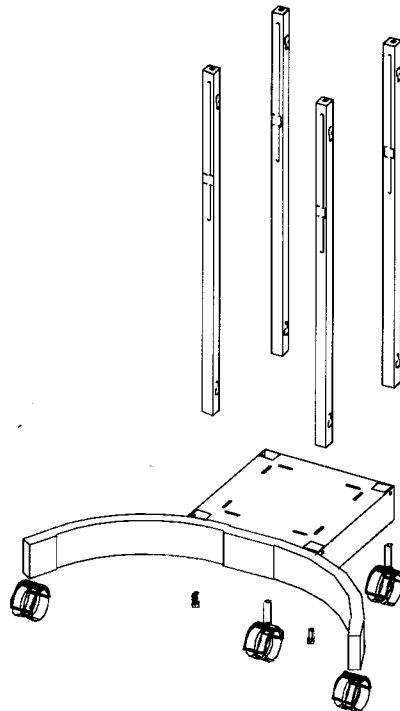

Figure 2: Attaching the Uprights and Rear Casters to Stand Base

**Step 3: Attach Monitor Shelf to Uprights**

- A) Attach Monitor Shelf to Uprights by lining up the Shelf's shoulder rivets with the Uprights and pushing it down into place.
- B) Screw Shelf to Uprights with four ¼-20 x 0.5" Button Head Screws.

Use the supplied 5/32" Allen wrench.

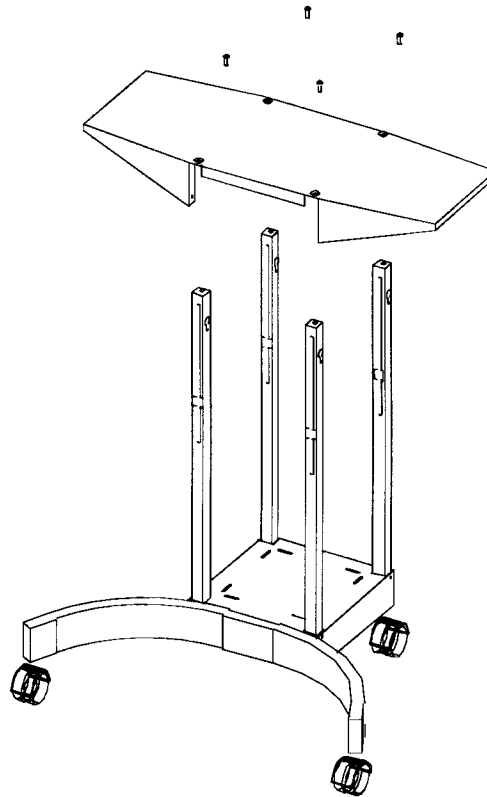

Figure 3: Attaching Monitor Shelf to Uprights

**Step 4: Attach Console Shelf to Assembly**

- A) Install four  $\frac{1}{4}$  round 8-32 x  $\frac{1}{2}$ " Nylon Standoffs on back side of Console Shelf.
- B) Place Push-Pull Latch (i.e., the Adjustable Clamping Handle) through hole in Shelf and screw on Nut Plate. Repeat for second Latch.

**Note:** The 'gap' between the Nut Plate and Shelf should be as tight as possible while still allowing you to slide Shelf upwards (as in the next step, 4-C). Adjusting this 'gap' space may require some trial and error.

- C) Fit the Shelf onto the Front Upright Legs by placing its Nut Plates through the Upright's square holes and sliding the Shelf upwards along the slots.
- D) Tighten Push-Pull Latches to secure Shelf.

The Push-Pull Latches operate like a ratchet wrench, allowing you to secure the Shelf to the Stand a half revolution at a time.

For each revolution, push the Latch 'in' and rotate clockwise to tighten; then pull the Latch 'out' and rotate counterclockwise to reset. Repeat this process until the Latch has secured the Shelf to the Stand.

- E) Install square Upright Plugs into the square holes on front Uprights.

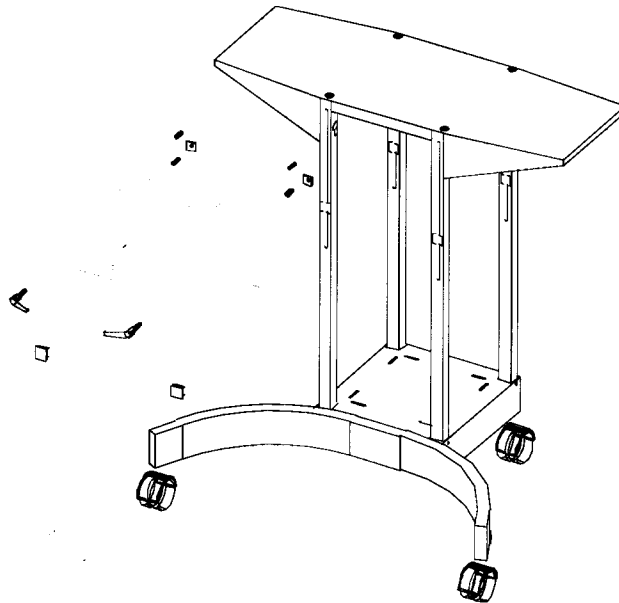

Figure 4: Attaching Console Shelf to Assembly

**Step 5: Attach Power Supply Box And Modesty Panel To Assembly (Optional)**

*[Skip this step if you are not using the Power Supply Box or Modesty Panel.]*

- A) Plug Power Cord into the Console Power Supply.
- B) Place Console Power Supply in the Power Supply Box.
- C) Attach the Power Supply Box to Stand.

Note that there are two tabs, or extensions, on the box; the larger one has a hole for a screw. First, slide the shorter tab into the slot on the rear of the Stand Base, then secure the larger flap to the Stand Base with the M4 x 6.0mm Pan Head Screw.

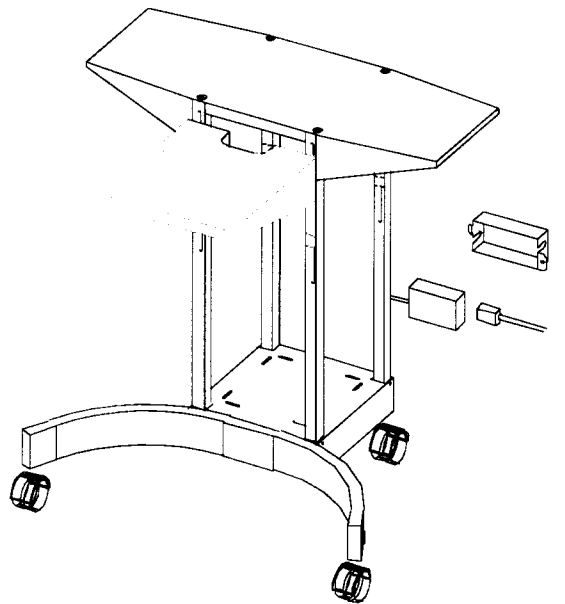

Figure 5: Attaching the Power Cord and Power Supply Box to Assembly.

- C) Attach Modesty Panel. (Optional)

Angle the Modesty Panel behind the Front Uprights and flip it up and forward between the two Uprights so that it locks into place.

**Note:** The top part of the Modesty Panel has an oval cutout.

- B) Install the CPU Tower sideways on the Stand Base.

Position the Tower so that the four nubs on its bottom extend over the sides of the Stand Base Plate.

**Note:** It is not necessary to secure the CPU Tower in from the underside of the Stand Base using this orientation.

- C) Connect Cables, according to Operating Manual.

When moving the Tower from room to room, take care to hold the Tower in place.

### To Install Tower Front-To-Back or Back-To-Front:

- A) Unscrew the four plastic Tower feet. (Save the screws.)

Position the Tower front-to-back or back-to-front on the Stand's Base Plate, so that two of the nubs on its bottom protrude through the two oval cutouts on the Base Plate.

**Note:** The Tower will overhang the Base Plate by several inches in this orientation.

- B) Use an M4 x 0.7 x 11mm Thumbscrew, Washer and 3/8-16 Hex Nut to secure each nub to the Stand Base.

**Note:** Washers mount between the Thumbscrew and the Hex Nut.

**Note:** Care must be taken when moving the stand with these Thumbscrews attached.

- C) Connect Cables, according to Operating Manual.

### To Install The Tower on a flat surface:

- A) Place the Tower on the ground, to the side of the stand.

- B) Extend the plastic feet to their open position by pulling each foot away from its pair-mate.

This will provide the most stability.

**Important:** Do not remove the Tower Feet when installing the Tower on a flat surface.

For longer cables, contact your Orban dealer.

- C) Connect Cables, according to Operating Manual.

---



**H A Harman International Company**

1525 ALVARADO STREET, SAN LEANDRO, CA 94577 USA

Phone: (1) 510/351-3500; Fax: (1) 510/351-0500; E-Mail: [custserv@orban.com](mailto:custserv@orban.com); Web: <http://www.orban.com>  
P/N: 95375.000.02